

**Electrical connection data**  
Boilers from 149 kW to 800 kW

Connection	Hardwiring 400V / 3N PE
Protection	C 32A
RCD switch	Type A IΔN 300mA

**Technical data RHK-AK 800**  
without e-filter

transport width (mm)	1960
transport length (mm)	4700
transport height (mm)	1960
width with cover panel (mm)	2146
length with cover panel (mm)	5086
height with cover panel (mm)	2066
water content (l)	3940
weight (kg)	9900
heat exchanger surface (m <sup>2</sup> )	74
continuous heat load (kW)	*720 / **640
*wood chips/ **pellets	
heating output (kW)	800
CO <sup>2</sup> (%)	10,0
efficiency (%)	>90
flue gas mass flow (kg/s)	0,525000
flue gas temperature (°C)	180
flue depress (PA)	40
flue depress with underpressure monitoring (PA)	10
drop at dT 10 pressure K (mbar)	296,80
max. pressure (bar)	3
flow heat (DN)	125
heat return(DN)	125
safety flow (DN)	80
safety return(DN)	80
filling and emptying (inch)	2
thermowell (inch)	1/2
flue gas pipe diameter (mm)	400
min. opening for air supply (cm <sup>2</sup> )	1650
min. volume flow rate for return temp. increase at 15K (m <sup>3</sup> /h)	16,24

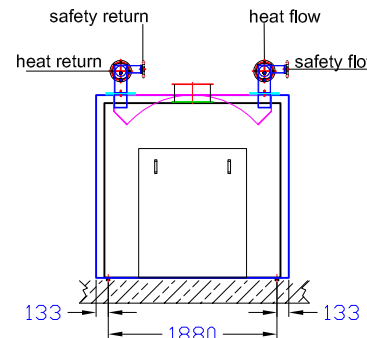
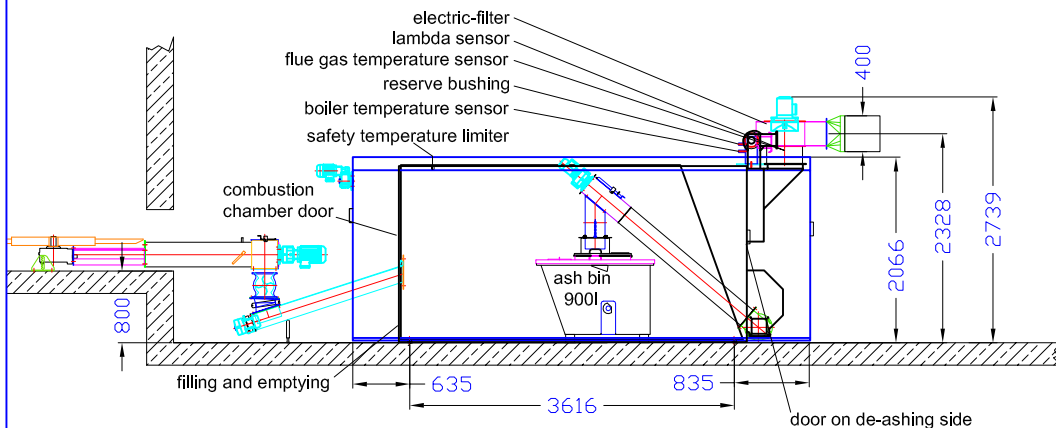

The boiler should be accessible from three sides. The discharging system should not cross the heating room.  
Room height and position of the particle separator(s)\* should be discussed with the Heizomat team.  
Connecting points for the necessary potential equalization on the boiler see supplementary sheets "Connection of the Heizomat boiler system to the main potential equalization of a building" \*.

Technical changes that serve the permanent further development remain reserved.

\*Optional equipment, depending on the statutory provisions for the country of destination.

Status 01.07.2017



Heizomat GmbH Gerätebau- Energiesysteme  
Maicha 21 - 91710 Gunzenhausen - 09836/9797-0